



VBV-770FM vehicle CCTV monitor

Quick installation guide

Guide d'installation rapide

Kurzanleitung

Guida di installazione rapida

Guía rápida de instalación

Snelle installatie handleiding

Guia rápida de instalação

Руководство по быстрой установке

Skrócona instrukcja instalacji

Hızlı Montaj Klavuzu

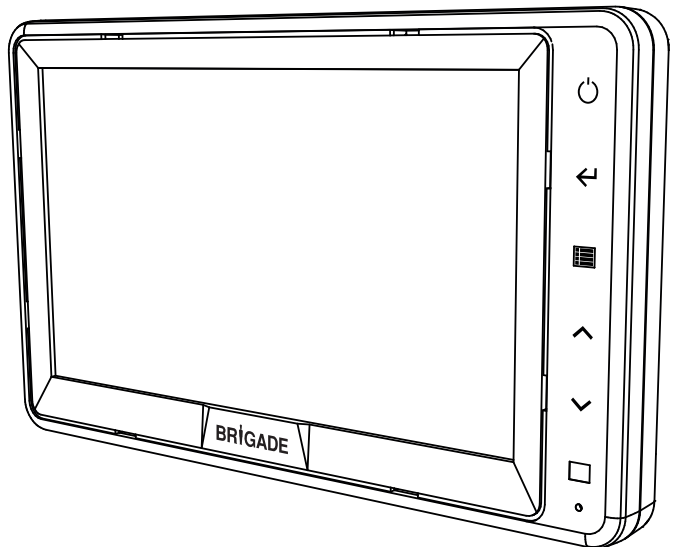

1 Contents

Contenu/Inhalt/Contenuto/Contenido/inhoud/Conteúdo/Содержание/ Zawartość/
İçerik

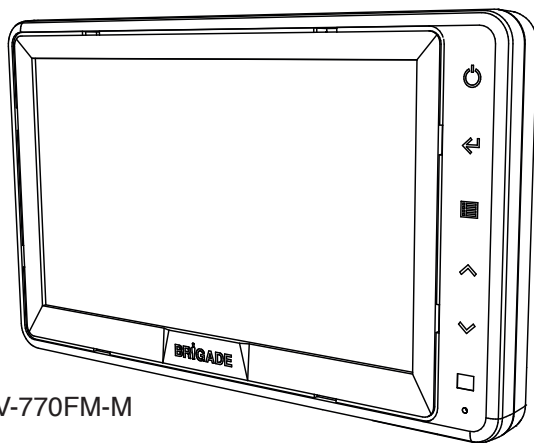

VBV-770FM-M

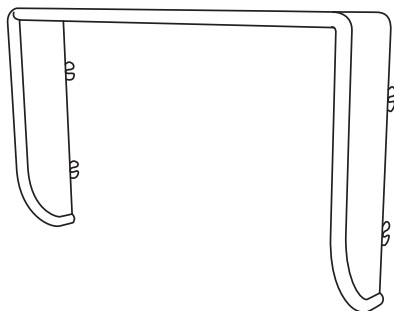

VBV-770M-SS

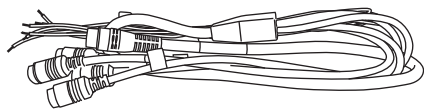

VBV-7XXFM-CA

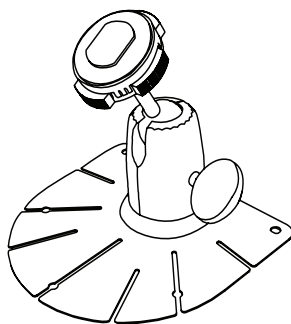

BMM-015

2 Monitor installation

Surveiller l'installation/Monitor-Einbau/Installazione del monitor/
Instalación del monitor/Monitor installatie/Instalação do monitor/
Расположение камеры/Monitör Montaji/Instalacja monitora

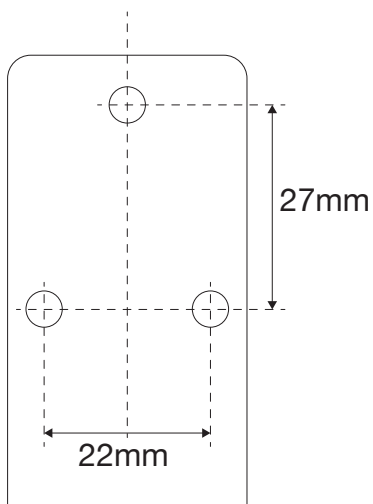
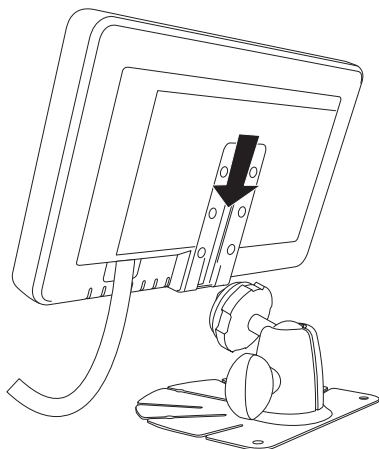
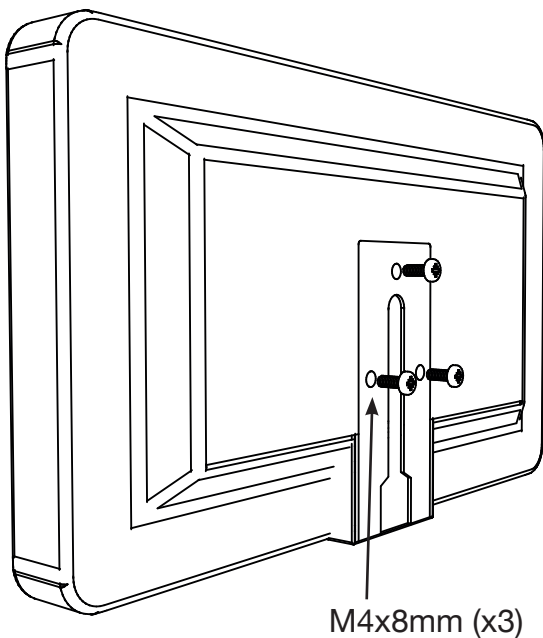
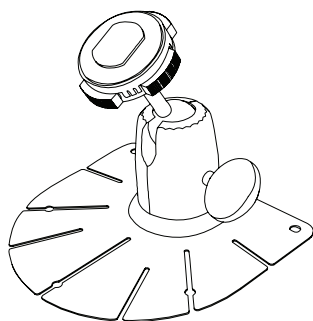
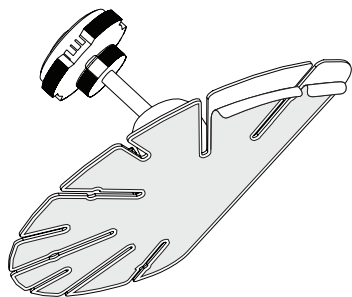

3 Connections

Connexions/Anschlüsse/Connessioni/Conexiones/Aansluitingen/Conexão/Сигнал скорости/ Podłączenia/Bağlantılar

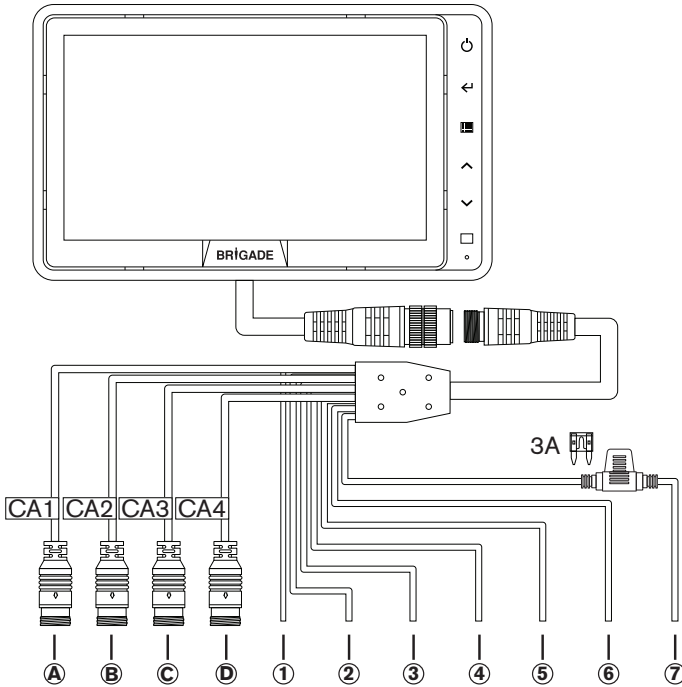

Camera	A	Trigger	White		Blue	Green	Brown
Caméra	CA1	Déclencher	Blanc		Bleu	Vert	Brun
Kamera	B	Trigger	Weiß		Blau	Grün	Braun
Telecamera	CA2	Attivare	Bianco		Blu	Verde	Marrone
Cámara	C	Desencadenar	Blanco	1	Azul	Verde	Marrón
Camera	CA3	Trekker	Wit		Blauw	Groen	Bruin
Câmera	CA3	Gatilho	Branco		Azul	Verde	Marrom
камера	D	триггер	белый		синий	зеленый	коричневый
Kamera	CA4	Włacznik	Biały		Niebieski	Zielony	Brazowy
Kamera		Tetik	Beyaz		Mavi	Yeşil	kahverengi
Yellow	5	Black	Ground		Red	Power	
Jaunes		Noir	Masse		Rouge	Positif	
Gelb		Schwarz	Masse		Rot	Betriebsspannung	
Giallo		Nero	Massa		Rosso	Positivo	
Amarillo		Negro	Masa	6	Rojo	Positivo	
Geel		Zwart	Grond		Rood	Vermogen	7
Verde		Preto	Massa		Vermelho	Positivo	
зеленый		черный	заземление		Czerwoný	красный	мощность
Zielony		Czarny	Masa		Czerwony	Zasilanie	
Sarı		Siyah	Eksi		Kırmızı	Artı	

4 Controls

Contrôles/Bedienung/Controlli/Controles/Controles/Controles/контроля/
Sterowanie/Kumandalar

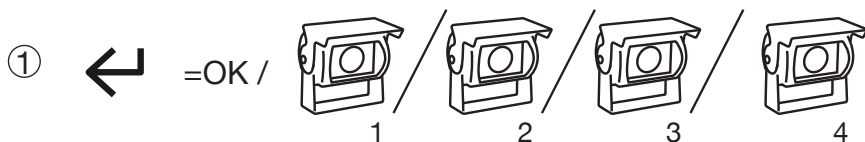
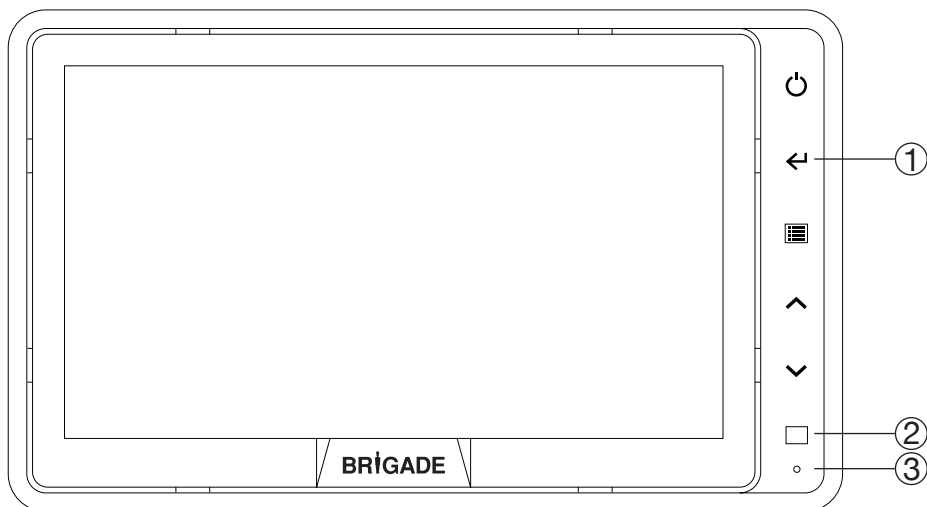

- ①
- ② Remote control receiver
Récepteur de la télécommande
Empfänger für Fernbedienung
Ricevitore per telecomando
Receptor de control remoto
Afstandsbediening ontvanger
Receptor de controle remoto
Приемник дистанционного управления
CzuJNIk pilota
Uzaktan Kumanda Algılayıcısı
- ③ Automatic low light sensor
Capteur optique automatique de basse luminosité
Licht Sensor
Sensore automatico di bassa luminosità
Sensor automático de baja luminosidad
Automatische lage lichtsensor
Sensor de luz baixa automática
Автоматический датчик низкой освещенности
Automatyczny czujnik światła
Düşük Işık Sensörü

5 Operation

Opération/Betrieb/Operazione/Operación/Werking/Operação/операция/ Çalıştırma/ Użytkowanie

Marker setting

Mise en marqueur/Einstellung der Markierungen/Impostazione dei marcatori/ Ajuste de los marcadores/Marker instelling/Definir os marcadores/установкой бита/ İşaretleyci Ayarı/Ustawienia znacznika

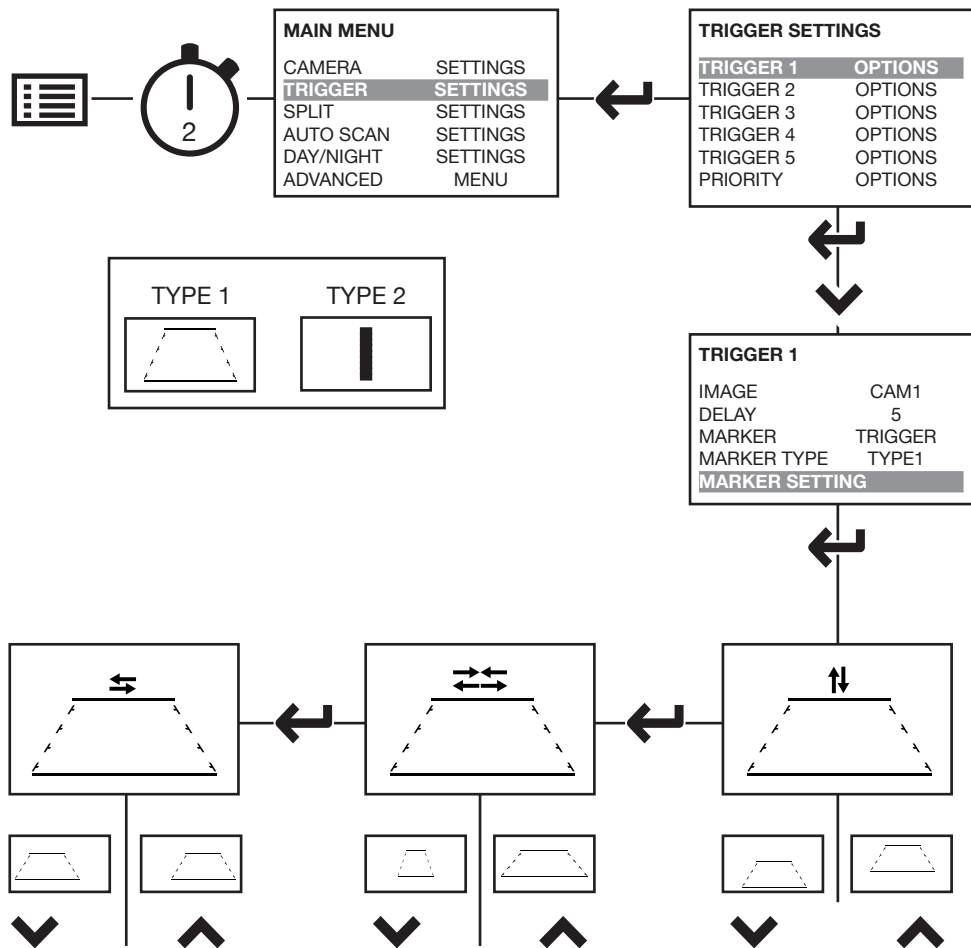

5 Operation

Opération/Betrieb/Operazione/Operación/Werking/Operação/операция/ Çalıştırma/ Użytkowanie

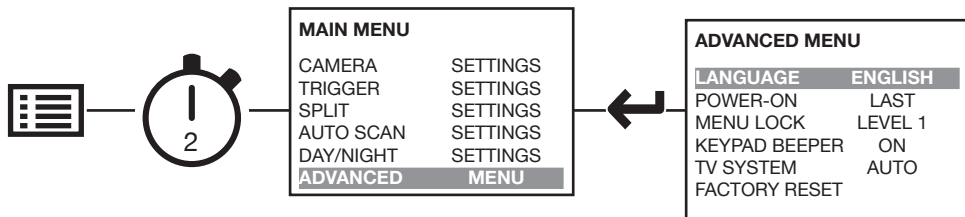

Button lock

Bouton de verrouillage/Tastensperre/Blocco dei Pulsanti/Bloqueo de botones/ Knopvergrendeling/Bloqueio dos botões/кнопка блокировки/Düğme kilidi/ Przycisk blokady



LEVEL 1



=



LEVEL 2



=

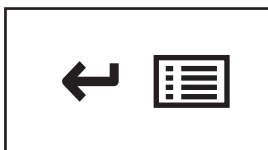

LEVEL 3



=

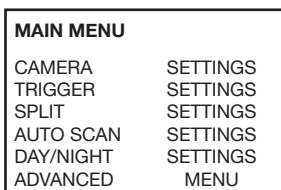

5 Operation

Opération/Betrieb/Operazione/Operación/Werking/Operação/operação/Użytkowanie/Çalıştırma

Split setting

Mise en diviser/Split-Einstellung/Impostazione Divisione/Ajuste de la Division/Split instelling/Definir Divisão/сплит настройки/podział ustawienie/bölünmüş ayarı

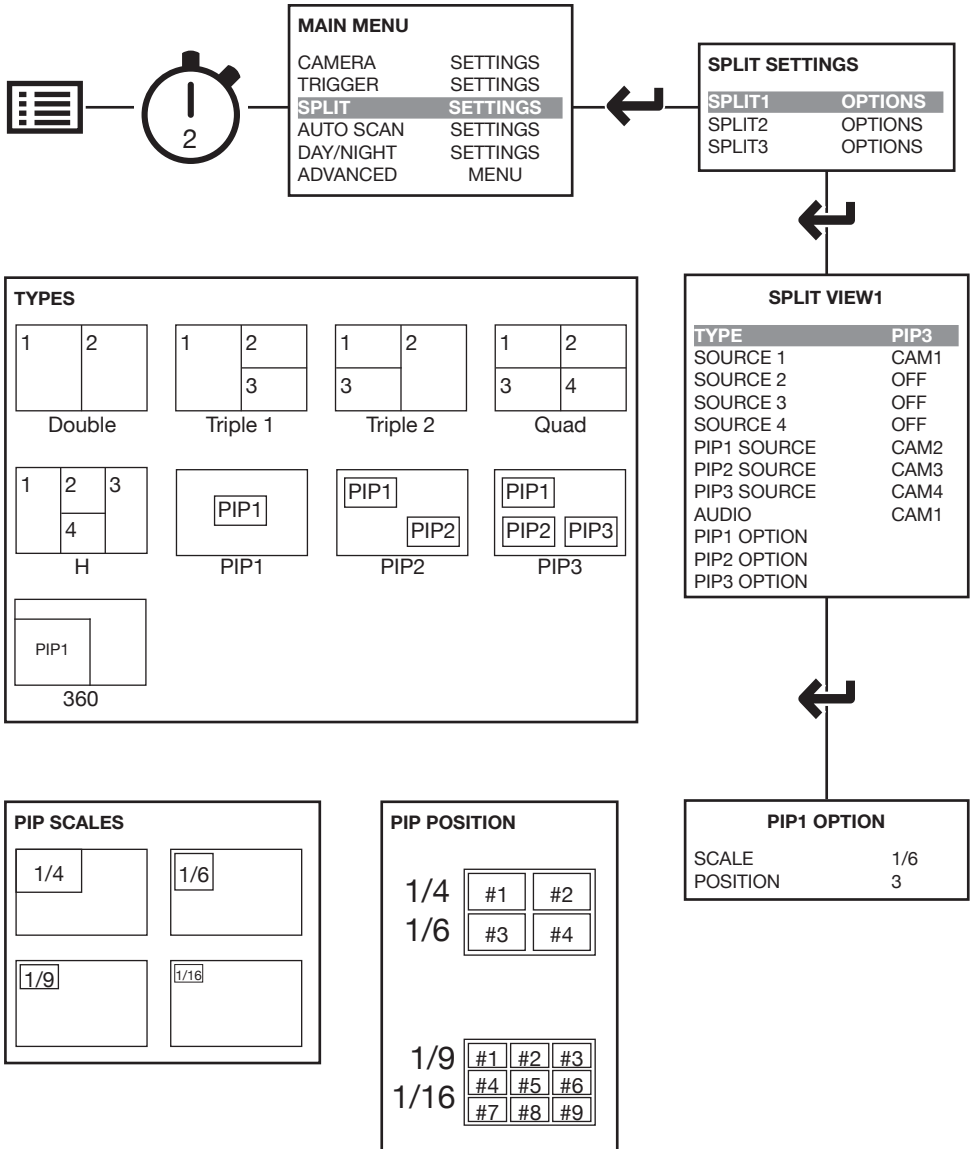

6 Specifications

Spécifications/Spesifikationer/Specifiche/Especificaciones/Specificaties/
Especificações/Спецификация/Specyfikacja/Özellikler

ENGLISH	
Specifications	
Monitor	VBV-770FM
TV system	NTSC / PAL
Picture	7" Digital TFT LCD colour monitor with on-screen display function
Display size	7" diagonal
Field of view	Top: 50°, Bottom: 70°, Left: 70°, Right: 70°
Resolution	(800x3(RGB)x480)
Picture image	Normal - Mirrored via OSD
Power	12/24Vdc input
Inputs	4 x camera
Dimensions	195.5(w) x 117.5(h) x 25.5(d)mm 7.6(w) x 4.6(h) x 1(d) inches
Operating temperature	-30°C ~ +70°C / -22°F ~ +158°F

DEUTSCH	
Spezifikationen	
Monitor	VBV-770FM
TV-System	NTSC / PAL
Bild	7" digitaler TFT LCD Farbmonitor mit Funktionsanzeige (OSD)
Bildschirmgröße	7" Diagonale
Blickwinkel	Oben: 50°, Unten: 70°, Links: 70°, Rechts: 70°
Auflösung	(800x3(RGB)x480)
Videobild	Normal - Spiegelbild durch OSD
Stromversorgung	12/24Vdc Eingang
Eingänge	4 x Kamera
Abmessungen	195,5(B) x 117,5(H) x 25,5(T)mm 7,6(B) x 4,6(H) x 1(T) Zoll
Betriebstemperatur	-30°C ~ +70°C / -22°F ~ +158°F

ESPAÑOL	
Especificaciones	
Monitor	VBV-770FM
Sistema de TV	NTSC / PAL
Imagen	Monitor a color de 7" digital TFT LCD con visualización de las funciones (OSD)
Tamaño de pantalla	7" diagonal
Campo visual	arriba: 50°, abajo: 70°, a la izquierda: 70°, a la derecha: 70°
Resolución	(800x3(RGB)x480)
Imagen invertida de fábrica	Normal - espejo a través de OSD
Suministro de corriente	12/24Vdc entrada
Entradas	4 x cámara
Dimensiones	195,5(a) x 117,5(a) x 25,5(p)mm 7,6(a) x 4,6(a) x 1(p) pulgadas
Temperatura de servicio	-30°C ~ +70°C / -22°F ~ +158°F

FRANÇAIS	
Specifications	
Moniteur	VBV-770FM
Système TV	NTSC / PAL
Image	7" Numérique TFT LCD moniteur couleur avec affichage de fonction (OSD)
Dimension de l'écran	7" diagonale
Champ de vision	Haut: 50°, Bas: 70°, Gauche: 70°, Droite: 70°
Résolution	(800x3(RGB)x480)
Image vidéo	Normal - miroir via OSD
Alimentation	12/24Vdc input
Entrées	4 x caméra
Dimensions	195(l) x 117,5(h) x 25,5(p)mm 7,6(l) x 4,6(h) x 1(p) pouces
Température d'utilisation	-30°C ~ +70°C / -22°F ~ +158°F

ITALIANO	
Specifiche	
Schermo	VBV-770FM
Sistema TV	NTSC / PAL
Immagine	Display TFT LCD a colori da 7" con funzioni OSD
Dimensioni schermo	7" diagonale
Campo visivo	Alto: 50°, Basso: 70°, Sinistra: 70°, Destra: 70°
Risoluzione	(800x3(RGB)x480)
Immagine video	Normale - Specchio via OSD
Alimentazione	12/24Vdc ingresso
Entrate	4 x telecamera
Dimensioni	195,5(l) x 117,5(a) x 25,5(p)mm 7,6(l) x 4,6(a) x 1(p) pollici
Temperature di esercizio	-30°C ~ +70°C / -22°F ~ +158°F

NEDERLANDS	
Specificaties	
Monitor	VBV-770FM
TV-systeem	NTSC / PAL
Beeld	7" digitale TFT LCD kleurenmonitor met on-screen display functie
Displayformaat	7" diagonaal
Gezichtsveld	Boven: 50°, Onder: 70°, Links: 70°, Rechts: 70°
Resolutie	(800x3(RGB)x480)
Videobeeld	Normaal - gespiegeld via OSD
Stroomvoorziening	12/24Vdc Ingang
Ingangen	4 x camera
Afmetingen	195,5(b) x 117,5(h) x 25,5(d)mm 7,6(b) x 4,6(h) x 1(d) inches
Bedrijfstemperatuur	-30°C ~ +70°C / -22°F ~ +158°F

6 Specifications

Spécifications/Spesifikationen/Specifiche/Especificaciones/Specificaties/ Especificações/Спецификация/Specyfikacja/Özellikler

PORTUGUÊS	
Especificações	
Monitor	VBV-770FM
Sistema de TV	NTSC / PAL
Imagem	Monitor a color de 7" digital TFT LCD con visualización de las funciones (OSD)
Tamaño de pantalla	7" diagonal
Campo visual	arriba: 50°, abajo: 70°, izquierda: 70°, derecha: 70°
Resolución	(800x3(RGB)x480)
Imagen de vídeo	Normal - espejado via OSD
Suministro de corriente	12/24Vdc entrada
Entradas	4 x cámara
Dimensiones	195,5(l) x 117,5(a) x 25,5(p)mm 7,6(l) x 4,6(a) x 1(p) polegadas
Temperatura de servicio	-20°C ~ +70°C -4°F ~ +158°F

Русский	
Спецификация	
монитор	VBV-770FM
ТВ-система	NTSC/PAL (Автоматическое определение)
изображение	7 "TFT LCD цветной монитор с функцией индикации на экране
размер дисплея	7" диагональ
Угол обзора	топ: 50°, дно: 70°, слева: 70°, право: 70°
Разрешение	(800x3(RGB)x480)
фото изображение	Нормальный - Зеркальный с помощью экранного меню
Напряжение	12/24Vdc затраты
затраты	4 x камеры
размеры	195.5(ш) x 117.5(в) x 25.5(г)mm 7.6(ш) x 4.6(в) x 1(г) дюймов
Рабочая температура	-30°C ~ +70°C -22°F ~ +158°F

TÜRKÇE	
Özellikler	
Monitör	VBV-770FM
Tv Sistemi	NTSC / PAL (otomatik seçim)
Görüntü	7" TFT LCD Renkli Monitör (Ekranında Kumanda Görüntü Fonksiyonlu)
Ekran Ebadı	7" (çapraz)
Görüntü Alanı	Üst: 50°, Alt: 70°, Sağ: 70°, Sol: 70°
Ekran Çözünürlüğü	(800x3(RGB)x480)
Ekran Görüntüsü	Normal – OSD ile Ayna Görüntüsü
Güç	12/24 VDC besleme
Girişler	4 x Kamera Girişi
Ebatlar	195,5(g) x 117,5(y) x 25,5(d)mm 7,6(g) x 4,6(y) x 1(d) inç
Çalışma sıcaklığı	-30°C ~ +70°C -22°F ~ +158°F

POLSKI	
Specyfikacja	
Specyfikacja	VBV-770FM
System TV	NTSC/PAL (Auto detect)
Obraz	Kolorowy monitor LCD 7" funkcja OSD
Wielkość wyświetlacza	7 " przekątnej
Pole Widzenia	Góra: 50°, dół: 70°, lewo: 70°, prawo: 70°
Rozdzielczość	(800x3(RGB)x480)
Wyświetlany obraz	normalny lub obrocony lustrzany – ustawienia OSD
Zasilanie	12/24V Prąd Stały
Wejścia	4 x kamera
Wymiary	195,5(s) x 117,5(h) x 25,5(g)mm 7,6(s) x 4,6(h) x 1(g) cali
Zakres temperatur	-30°C ~ +70°C -22°F ~ +158°F

Disclaimer

Camera monitor systems are an invaluable driver aid but do not exempt the driver from taking every normal precaution when conducting a manoeuvre. No liability arising out of the use or failure of the product can in any way be attached to Brigade or to the distributor.

Dénégation

Les systèmes de moniteurs des caméras sont une aide précieuse pour le conducteur, mais celui-ci doit toutefois prendre toutes les précautions nécessaires pendant les manœuvres. Brigade ou ses distributeurs n'assument aucune responsabilité résultant de l'utilisation ou d'un défaut du produit.

Haftungsausschluss

Kamera-Monitor-Systeme sind für den Fahrer eine unschätzbare Hilfe, ersetzen aber beim Manövrieren keinesfalls die üblichen Vorsichtsmaßnahmen. Für Schäden aufgrund der Verwendung oder eines Defekts dieses Produkts übernehmen Brigade oder der Vertriebshändler keinerlei Haftung.

Condizioni di Utilizzo

I sistemi di telecamere e monitor costituiscono un prezioso ausilio alla guida, ma il conducente deve comunque assicurarsi di prendere tutte le normali precauzioni quando esegue una manovra. Né Brigade né il suo distributore saranno responsabili per eventuali danni di qualsiasi natura causati dall'utilizzo o dal mancato utilizzo del prodotto.

Aviso legal

Aunque los sistemas de cámaras con pantalla constituyen una valiosa ayuda, no eximen al conductor de tomar todas las precauciones normales al hacer una maniobra. Brigade y sus distribuidores comerciales no se responsabilizan de cualquier daño derivado del uso o de un mal funcionamiento del producto.

Specifications subject to change. Sous réserve de modifications techniques. Änderungen der technischen Daten vorbehalten. Specifiche soggette a variazioni. Las especificaciones están sujetas a cambios. Wijzigingen in specificaties voorbehouden. As especificações estão sujeitas a alterações. Спецификация может изменяться. Brigade Electronics belirttiği özellikleri haber vermeksizin istediği zaman değiştirebilir. Specyfikacja techniczna może ulec zmianie.

Declinación de responsabilidad

Os sistemas de monitoria da câmara são uma ajuda incalculável ao motorista, mas não dispensam o motorista de tomar todas as precauções normais ao realizar uma manobra. Nenhuma responsabilidade decorrente do uso ou falha do produto pode de forma alguma ser atribuída ao Brigade ou ao distribuidor.

Verwerping

De camera-monitorsystemen zijn een waardevolle hulp voor de bestuurder, maar ontheffen hem echter niet van de verplichting om het voertuig zorgvuldig te manoeuvreren. Brigade en zijn distributeurs zijn niet aansprakelijk voor schade door gebruik of het niet functioneren van het product.

Отказ от обязательств

Системы камерного слежения являются крайне полезным средством помощи водителю, но не освобождают водителя от обязанности соблюдения всех необходимых мер предосторожности при совершении маневра. На компанию Brigade или распространителя продукции не налагается никакая ответственность, возникающая по причине использования или неисправности данного продукта.

Uwaga

Wizyjny system wspomagania cofania jest niezastapioną pomocą dla kierowcy, ale jego posiadanie nie zwalnia z zachowania szczególnej ostrożności podczas manewrów. Żadna kolizja drogowa ani jej skutki nie mogą obciążać producenta urządzenia oraz jego dystrybutorów.

Hatırlatma

Kamera Maniör Sistemleri sürücünün önemli bir yardımcısı olmakla birlikte, manevra esnasında sürücü bir kaza olmaması için her türlü önlemi almalıdır. Brigade veya bölgesel dağıtıcıları yapılacak yanlış bir uygulama ve sonucunda oluşabilecek maddi ve/veya manevi kayıplardan sorumlu tutulamaz.

Serial No:

Stock code:



www.brigade-electronics.com

